



## 1. General

NJBK1 series motor protector (hereinafter referred to as the protector) is applicable to the protection of overload, loss of phase and three-phase current unbalance of none-stop or intermittent duty AC motors with AC 50Hz, rated insulation voltage below 690V and rated operating current 1A~400A. Standards:IEC/EN 60947-4-1

# NJBK1 Series Motor Protection Relays

## 2.Key Technical Parameters

Table 1 Ambient Conditions

Normal use conditions	Ambient temp.: -5 °C ~+40 °C ; average value within 24h not exceeding +35 °C ; altitude not exceeding 2,000m.
Atmospheric conditions	RH shall not exceed 50% when maximum temperature is +40 °C ; in case of lower temperature, higher RH is allowed. Measures should be taken against occasional condensation due to temperature change.
Installation category	III
Transport and storage conditions	-25°C ~+55°C

Table 2 Product Specifications and Main Technical Parameters

Model	NJBK1-80/5	NJBK1-80/10	NJBK1-80/30	NJBK1-80/80	NJBK1-400/200	NJBK1-400/400
Setting current (A)	5	10	30	80	200	400
Current setting range (A)	1~5	2~10	6~30	16~80	40~200	80~400
Motor power (kW)	0.5~2.5	1~5	3~15	8~40	20~100	40~200
Installation method	Guide rail type, device type					
Display method	LED					
Protection function	Overload, loss of phase and three-phase current unbalance					
Setting method	Knob					
Number of contacts	2 groups of normally open (95 and 98 are protection contacts, 07 and 08 are alarm contacts)					

Table 3 Main Circuit Technical Parameters

Product Model	NJBK1-80/5	NJBK1-80/10	NJBK1-80/30	NJBK1-80/80	NJBK1-400/200	NJBK1-400/400
Rated insulation voltage	690V					
Rated control supply voltage Us , frequency	85%Us~110%Us, AC220V、AC380V,50Hz					
Rated impulse withstand voltage Uimp	4kV					
Rated conditional short-circuit current	3kA					
Enclosure protection class (if applicable)	IP20					
Pollution class	Class 3					
Rated duty	8h duty or non-stop duty					
Electromagnetic environment	B					

Table 4 Auxiliary Circuit Technical Parameters

Product model	NJBK1-80、NJBK1-400
Rated insulation voltage (V)	415
Rated impulse withstand voltage Uimp (kV)	2.5
Contact capacity	Ue/Ie:415V/0.95A,240V/1.5A;Ith:5A

### 3. Structure characteristic

#### 3.1 Structure characteristic

3.1.1 Knob sets current value and trip grade.

3.2 LED displays the current value, setting state, fault code and other information about the maximum phase.

3.3 With overload inverse time-lag protection, open-phase protection, three-phase current unbalance protection and other functions.

3.4 5 optional built-in overload curves,meet the use at different occasions.

3.5 Test / Reset: Operating status, press "Test / Reset" button for a short time to conduct simulated action test, and press it for a long time to enter setup mode; press this button to reset under fault conditions.

3.6 Pluggable terminal blocks, facilitate user connection.

3.7 Integrated design, simple structure, two installation methods of guide rail installation and screw mounting.

3.8 Fault memory and its instruction. In case of motor failure, LED flashes alternately and displays the fault code and maximum phase current value.

### 4. Protective characteristics

#### 4.1 Overload operating characteristics

Overload curve	Action time(s)	Overload multiple							Remark
		1.05	1.2	1.5	2	5	6	7.2	
Kr=1		No action	63	40	22	3.6	2.5	1.8	Conform to Class 5
Kr=2		No action	125	80	45	7.2	5	3.5	Conform to Class 10A
Kr=3		No action	250	160	90	14	10	6.9	Conform to Class 10
Kr=4		No action	500	320	180	29	20	14	Conform to Class 20
Kr=5		No action	750	480	270	43	30	21	Conform to Class 30

#### 4.2 Open-phase protection action characteristic

When any one phase current of the three-phase current of the main circuit is 0, the protector acts for 3s, with a relative error of±20%.

#### 4.3 Action characteristics of three-phase current unbalance protection

When three-phase current of the main circuit complies with the formula below, the protector acts for 3s, with a relative deviation of±20%.

$$\frac{\sum_{i=1}^3 I_i^2}{I_{avg}^2} \times 100\% > 30\%$$

Where:

I<sub>i</sub>: Current effective value per phase

I<sub>avg</sub>: Average value of three-phase current effective value

Tripping characteristic curve

4.4 Tripping characteristic

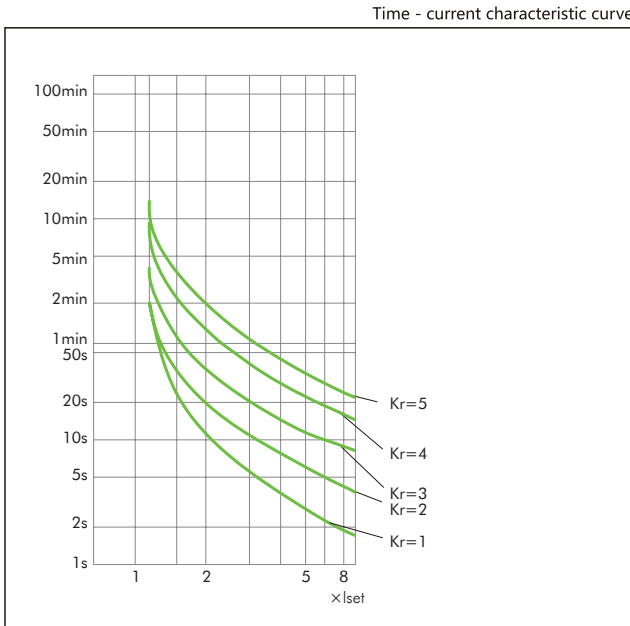

6. Overall and mounting dimensions (mm)

5. Wiring diagram

Control power supply voltage AC220V wiring diagram

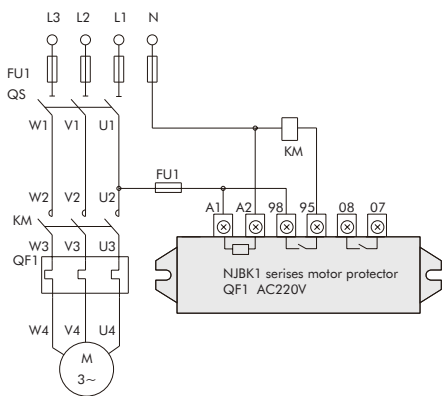

Control power supply voltage AC380V wiring diagram

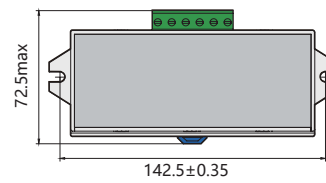
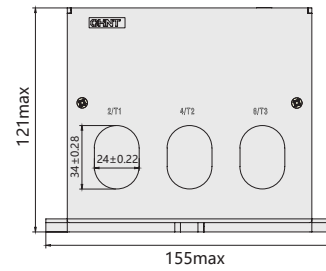
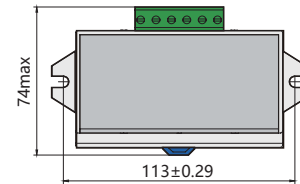
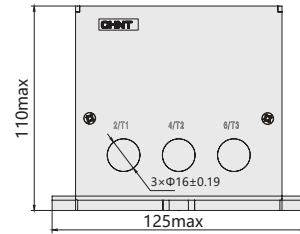
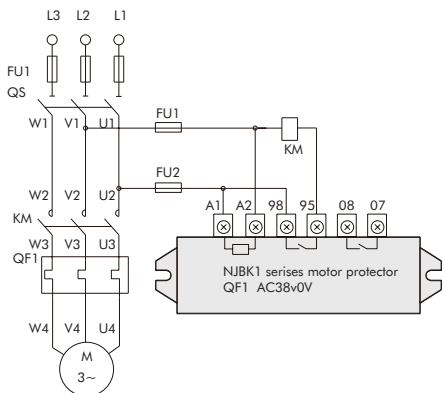

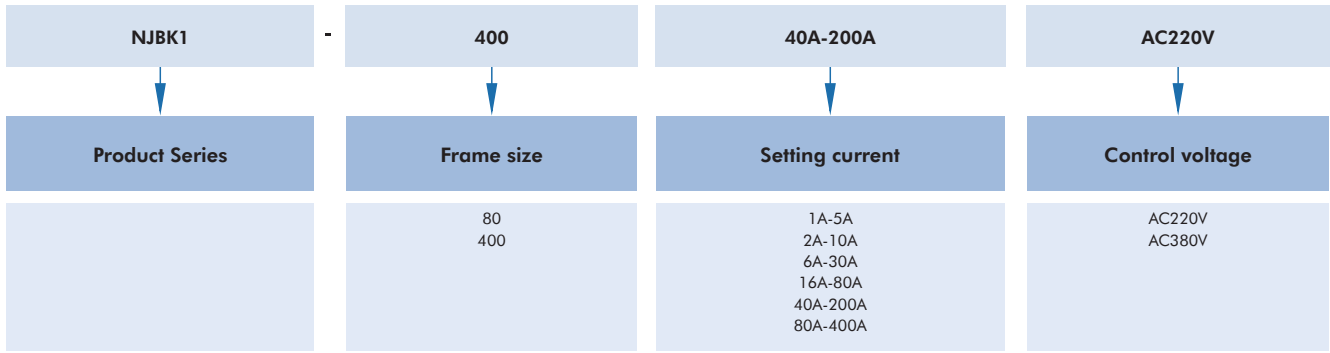

Setting current	Matched motor power	Control voltage	Contact ability	Description	Code
40A-200A	20~100kW	AC220V	240V/1.5A,lth:5A	NJBK1-400 40A-200A AC220V	789004
40A-200A	20~100kW	AC380V	240V/1.5A,lth:5A	NJBK1-400 40A-200A AC380V	789005
80A-400A	40~200kW	AC220V	240V/1.5A,lth:5A	NJBK1-400 80A-400A AC220V	789006
80A-400A	40~200kW	AC380V	240V/1.5A,lth:5A	NJBK1-400 80A-400A AC380V	789007
1A-5A	0.5~2.5kW	AC220V	240V/1.5A,lth:5A	NJBK1-80 1A-5A AC220V	281180
1A-5A	0.5~2.5kW	AC380V	240V/1.5A,lth:5A	NJBK1-80 1A-5A AC380V	281181
2A-10A	1~5kW	AC220V	240V/1.5A,lth:5A	NJBK1-80 2A-10A AC220V	281182
2A-10A	1~5kW	AC380V	240V/1.5A,lth:5A	NJBK1-80 2A-10A AC380V	281183
6A-30A	3~15kW	AC220V	240V/1.5A,lth:5A	NJBK1-80 6A-30A AC220V	281184
6A-30A	3~15kW	AC380V	240V/1.5A,lth:5A	NJBK1-80 6A-30A AC380V	281185
16A-80A	8~40kW	AC220V	240V/1.5A,lth:5A	NJBK1-80 16A-80A AC220V	281186
16A-80A	8~40kW	AC380V	240V/1.5A,lth:5A	NJBK1-80 16A-80A AC380V	281187