



NJX3 Series Miniature Relays

1. Scope of application

1.1 Three contact forms, namely 1Z, 2Z and 3Z; it has the characteristics of small size, low power dissipation, big load capacity, and high reliability. It's extensively used in the HVAC industry for the control of industrial equipment such as condenser, compressor and air-conditioning. It needs no socket and realizes wire connection using quick-connect terminals, which is flexible and convenient.

1.2 Certificate: UL, CE.

2. Working conditions

Temperature Range	-45°C ~ +65°C
Relative humidity	Reaching 95% at +25°C
Atmospheric pressure	86kPa~106kPa
Elevation	≤2000m

3. Major parameters and technical performance

3.1 Contact parameters

Contact form	1Z,2Z,3Z		
Initial contact resistance	100mΩ		
Contact material	Silver alloy		
Contact Ratings	Electrical Operating Cycles	Load Type	Surrounding Air Temperature (SAT)/Ambient (°C)
Rated Voltage/ Rated Current			
277VAC/15A	100000	Resistive	SAT 65
230VAC/1HP	6000	HP	SAT 65
600VAC/6.8A	6000	GP	SAT 65
28VDC/10A	100000	Resistive	SAT 65
Mechanical endurance	2 million times		

3.2 Performance and characteristic parameters

Insulation resistance	1000MΩ(500VDC)
Dielectric withstand voltage	Between contact coils:2200VAC Between break contacts:800VAC
Operate time (25°C ,rated voltage)	≤ 15ms
Release time (25°C ,rated voltage)	≤ 15ms
Shock(stability)	Acceleration 100m/s ² Pulse duration 11ms
Vibration	Double-amplitude 1mm,10~55Hz
Leading-out terminal form	Quick-connect terminal
Overall dimension(mm)	64.3×34.5×57.2

3.3 Coil parameters

Pull-in voltage	≤85% rated voltage
Release voltage	≥20% rated voltage
Peak voltage	110% rated voltage

3.3 Coil parameters

Rated voltage VAC	Operate voltage \leq VAC	Release voltage \geq VAC	Coil resistance Ω
24	20.4	4.8	$42 \times (1 \pm 10\%)$

Note: The coil temperature parameter is value in 25 °C

4. Overall and installation dimension

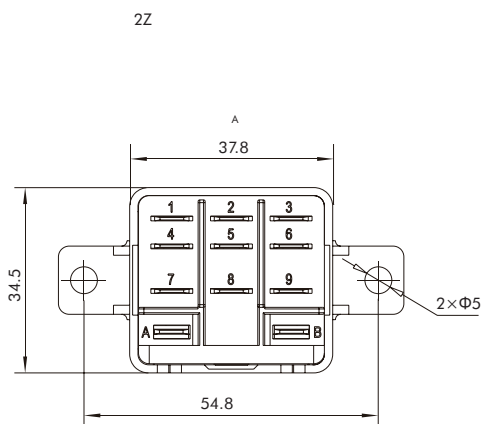
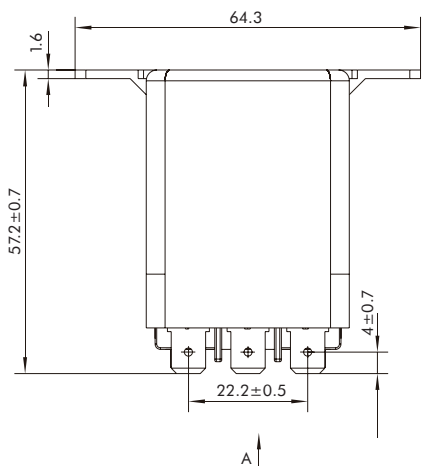
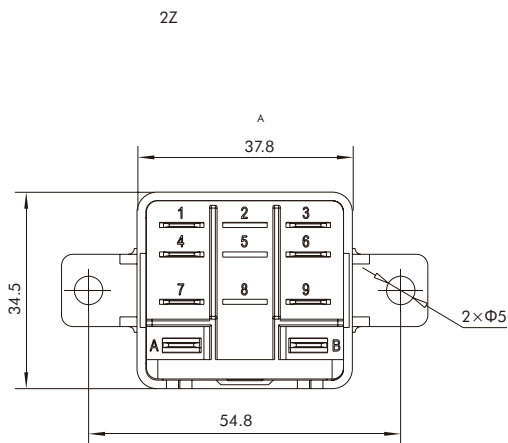
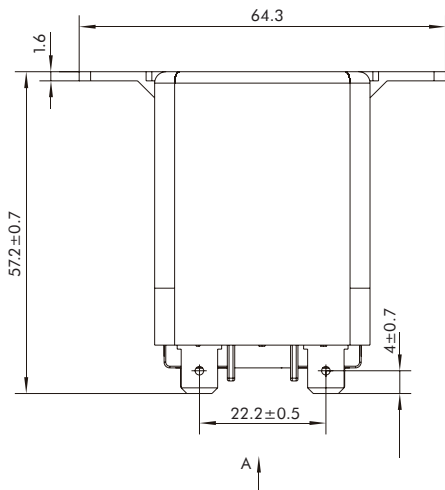
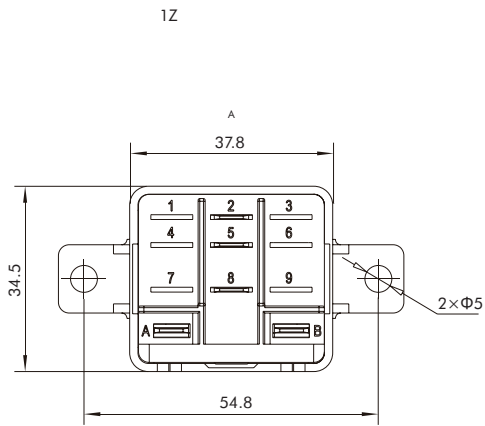
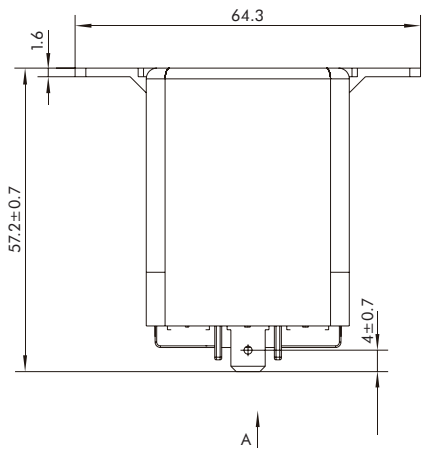

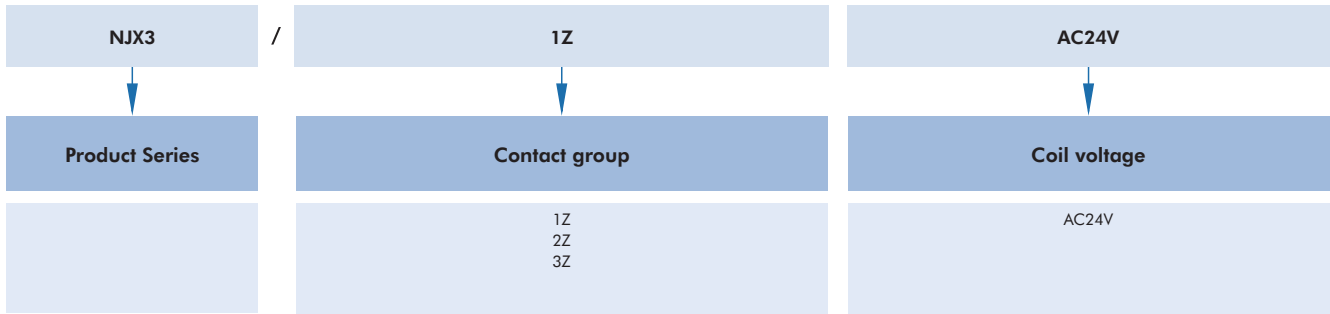

Contact	Rated current	Coil voltage	Model Description	Code
1Z	277V/15A	AC24V	NJX3/1Z AC24V	265325
2Z	277V/15A	AC24V	NJX3/2Z AC24V	265326
3Z	277V/15A	AC24V	NJX3/3Z AC24V	265327