

NKB1  
Control and Protection Switch

---

**User Instruction**

---



## Safety Warning

---

- ① Only professional technicians are allowed for installation and maintenance.
- ② It is strictly prohibited to install in the environment containing inflammable, explosive gas and moist condensation.
- ③ Power must be turned off when installing, maintaining and maintaining the product.
- ④ When the product is being installed, only standard wires can be used to connect the product to acceptable power and load.
- ⑤ It' s prohibited touching the conductive part when the product is operating.
- ⑥ The product should be stored and transported under dry and well-ventilated conditions, without strong impact and vibration, direct sunlight, rain, dust and corrosive chemical gas.

### 1 Use Purpose

NKB1 series control and protection switch (CPS) can be used to connect, carry and disconnect current under normal conditions (including specified overload conditions). It can also be used to connect and carry (for a period of time) and disconnect current under specified abnormal conditions (such as short circuit).

Schematic diagram:



### 2 Type Key and Definitions

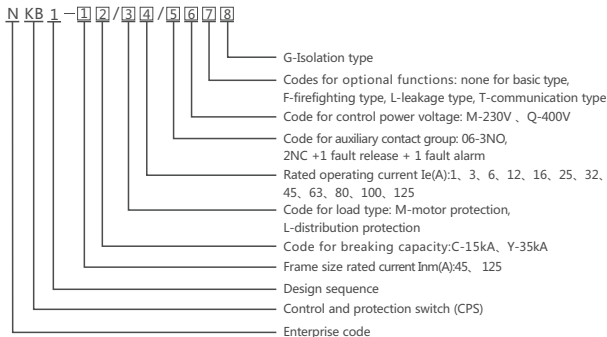

Note: these are all isolated type products (G-handle with isolation lock)

### 3 Key Technical Parameters

**Table 1 Key Technical Parameters**

Model		NKB1-45	NKB1-125		
Ambient conditions	Ambient temp. (°C)	-5°C~+40°C			
	Hot and humid atmospheric conditions	+40°C, relative humidity 50%; up to 90% at +25°C			
	Altitude	No influence below 2,000m			
	Pollution class/installation category	Class 3/III			
	Rated operating voltage Ue (V)	400, 690			
	Frequency (Hz)	50Hz(60Hz)			
	Rated insulation voltage Ui(V)	690V			
	Rated impulse withstand voltage Uimp(kV)	4		6	
	Conventional thermal current Ith(A)	16		45	80 125
	Rated operating current Ie(A)	1	3	6 12 16	25 32 45 63 80 100 125
	Application category	AC-43 AC-44			
	Number of poles	3P			
	Duty class (intermittent duty)	300 load factor 40%		120 load factor 25%	

**Table 2 Setting current of controller**

Frame size	Rated operating current Ie (A)	Rated current of controller Iet (A)	Range of overload setting current Ir1 (A)	Controllable motor power Pe (kW)(400V)
45	1	1	0.4~1	0.12~0.3
	3	3	1.2~3	0.37~1.2
	6	6	2.4~6	1.0~2.7
	12	12	4.8~12	2.2~5.5
	16	16	6.4~16	3.0~7.5
	25	25	10~25	5.0~12
	32	32	12.8~32	6.5~15
125	45	45	18~45	9.0~22
	63	63	25~63	12~30
	80	80	32~80	15~37
	100	100	40~100	22~45
	125	125	50~125	27~55

**Table 3 Operation conditions for controlling electromagnet**

Rated control power voltage Us	Conventional operation	Operating voltage range
M:AC230V Q:AC400V	CPS reliable closing	(85%~110%)Us
	CPS disconnect or release	(20%~75%)Us

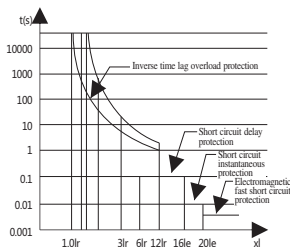

Figure 1 NKB1 time-current operating characteristics

## 4 Main Features and Operating Principles

NKB1 series product adopts modular design and integrated structure that combines circuit breaker, contactor, overload relay, starter and isolator. It can be used either for automatic remote control or direct on-site manual control. It is equipped with various functions such as panel indication, electromechanical signal alarm, overvoltage/ undervoltage protection and phase loss/phase failure protection.

With its compact and robust design, the product can provide comprehensive protection and precise and reliable operations for all kinds of motor start and control circuits as well as distribution circuits based on its features such as high short circuit breaking capacity and short flashover distance, and its various optional protection functions such as inverse time lag overload long time delay, short circuit short time delay, instantaneous short circuit protection and fast short circuit protection.

The product mainly consists of body part, electromagnetic transmission mechanism, operation mechanism, main circuit contact groups, smart release and auxiliary contacts. It can be used for connection and disconnection of on-site or remote control circuits.

### 4.1 Functional Parameters and Factory Settings

Refer to Table 4 for the functional parameter settings and protection features of NKB1 smart controller

**Table 4 Functional parameter settings**

Functions	Parameter settings	Delay time settings	Factory settings	User configurable parameters	Fault status output	
					Basic type	Firefighting type
Overload protection	(0.4~1) Ie	Code for protection curve	F1	(0.4~1) Ie	Delayed release	Delayed alarm
Short circuit short time delay protection	(3~12)Ir+(0)	0.3~0.6s	8Ir/0.4s	(3~12)Ir+(0)	Delayed release	Delayed alarm
Short circuit instantaneous protection	45 type (6~16)Ie	-	14Ie	(6~16)Ie	Instantaneous release	Release
	125 type (6~14)Ie		12Ie	(6~14)Ie		
Unbalance (phase loss/failure) protection	(20%~80%)+(0)	1~40s	30%/10s	(20%~80%)+(0)	Delayed release	Delayed alarm (phase failure release)
Undercurrent protection	(0.2~0.8)Ir+(0)	1~60s	(0)	(0.2~0.8)Ir+(0)	Delayed release	Delayed alarm
Undervoltage protection	Us 230V (154V~198V)+(0)	1~30s	176V/10s	(154V~198V)+(0)	Delayed release	Delayed alarm (release)
	Us 400V (266V~342V)+(0)	1~30s	304V/10s	(266V~342V)+(0)		
Overvoltage protection	Us 230V (230V~286V)+(0)	1~30s	264V/10s	(230V~286V)+(0)	Delayed release	Delayed alarm
	Us 400V (400V~494V)+(0)	1~30s	456V/10s	(400V~494V)+(0)		
Start delay	(0~99s)+(0)	0~99s	3s	(0~99s)+(0)	Start delay shielded part protection, short circuit instantaneous release	
Lock-rotor protection	(5~9)Ir+(0)	1~50s	(0)	(5~9)Ir+(0)	Delayed release	Delayed release
Residual current protection	(30~500mA)+(0)	0.1~1s	100mA	(30~500mA)+(0)	Release	Alarm
Note: communication and leakage types are optional: communication type uses RS485 line and Modbus protocol. Overload protection setup (1.5Ir operation time s): F0(shut-off overload protection), F1 (51), F2 (98), F3 (144), F4(200). The power signal of overvoltage /undervoltage protection for controller is collected from control terminal Us (A1-A2). Residual current is classified into: 30, 50, 75, 100, 150, 200, 300, 500 (mA). When the function parameter in the table is set to (0), it means the function is deactivated.						

#### 4.2 Controller Panel Introduction

Before connecting to the main circuit, user should set the long-time delay and short time-delay setting current to required value based on the load current of the circuit to be protected by NKB1. After power-on, the digital tube will be lit on and display auxiliary current and voltage value as well as the measured current value of phase A, B and C in cycle.

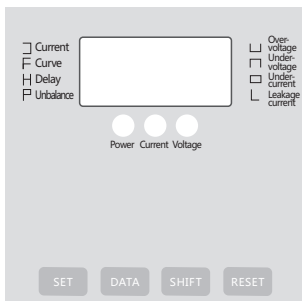

### 4.3 Operations

After the NKB1 is powered on, the LED will display voltage value. It can also be used as a voltmeter which will display voltage value in the last three digits.

The NKB1 can also be used as amperemeter during operation which will display the currents of three phases in cycle.

During operation, the power indicator of basic type NKB1 will remain solid, while the power indicator of firefighting type will flash.

### 4.4 Controller Menu (Protection Parameter Setup)

- Controller menu

Controller menu levels: open setup menu, hidden setup menu;

Open setup menu: user can conduct functional parameter setup as needed (refer to Table 4);

Hidden setup menu: user can switch between basic/firefighting type and set up communication address, baud rate and self-tuning function;

Fast recovery: If setup goes wrong, use this function to recover the controller to factory settings (refer to factory settings in Table 4);

Self-tuning: Conduct self-tuning after load running is stabilized, the controller will adjust current setting according to circuit parameters automatically.

Warning: Please use the hidden setup menu with care, in case you mess up the settings.

**Table 5 Controller menu**

Operation sequence	Display contents	Code definitions	Setting range	Factory settings
1st press of setup key	∩ 000	Long time delay setting current	(0.4~1) Ie	Customer requirement
2nd press of setup key	H 03	Start delay	0~99s	3s
3rd press of setup key	F	Overcurrent inverse time lag protection	Select from sequence 1~4	F1
4th press of setup key	P 30	3 phase unbalance %	(20%~80%)+(0)	30%
5th press of setup key	U	Overvoltage value	(230V~286V)+(0)	264V
6th press of setup key	V	Undervoltage value	(154V~198V)+(0)	176V
7th press of setup key	L	Code for current leakage value	Select from sequence 0~8	Customer requirement
8th press of setup key	□	Undercurrent value	(0.2~0.8) Ir+(0)	(0)
9th press of setup key	μ ∩ ∩	Factory settings	NO or YES	NO

- Protection parameter setup

When the motor is running, the setup key is invalid;

Open setup menu: When running at empty load, press setup key to select setup type; press the shift key to select data, then press data key to change data;

Hidden menu setup: When running at empty load, press and hold data key and shift key (4s) to enter hidden menu; press set key to select setup type; press the shift key to select data, then press data key to change data;

After finishing parameter setup, press set key again to enter next setup until you are done;

You don't have to set up the options you don't need. After finishing all the parameter setup, press reset key to quit setup status and save the settings. Now the display will show voltage value.

- Fast recovery operation

When running at empty load, select factory settings (μ), press data key and adjust to YES; press reset key to recover factory settings (initialization).

- Self-tuning operation









Press and hold data key and shift key (4s) to enter hidden menu, the display shows basic/firefighting (∩) switch; press setup key until the display shows self-tuning mode (□); press data key and adjust to YES; press reset key to quit the menu;

For basic type product, the power indicator will flash which means the product is in self-tuning status. When the indicator stops flashing, it means self-tuning is successful, and the switch returns to normal operation status. For firefighting type product, the power indicator remains solid which means the product is in self-tuning status, when the indicator starts to flash, it means self-tuning is successful, and the switch returns to normal operation status. If the indicator goes off, it means self-tuning is not successful, press reset key or reboot the switch to return to the original status.

#### 4.5 Fault Inquiry

Fault inquiry: run NKB1 at empty load, press reset key and compare with the panel fault type symbol and check the type of last fault; press reset key again and wait for about 20s, if the panel displays voltage value, it means NKB1 has quit fault inquiry and recovered to normal monitoring status.

**Table 6 Fault types**

Menu display	Fault type	Fault parameter
 67.5	Overload	Current67.5A
 483	Short circuit short time delay	Current483A
 650	Short circuit instantaneous	Current650A
 100	Phase missing	Phase missing
 38	3 phases unbalance	38%
 15	Undercurrent	Current15A
 268	Overvoltage	Voltage268V
 172	Undervoltage	Voltage172V
Return		

#### 4.6 Operaton Handle (Panel Instruction)

**AUTO:** (Auto control position), the electromagnet coil for switch control is connected, realizing auto remote control by connecting and disconnecting the control power.

**TRIP:** In case of fault release, the switch mechanism will release, and the main contact and the electromagnet coil are both disconnected.

**OFF:** Manual operation, the electromagnet coil is disconnected, and the main contact of the switch remains at disconnected position.







**RESET:** Rotate the operation knob to reset the released switch mechanism and make it ready for next release.

**Isolation status:** Pull out the isolation bar at disconnected position and lock it out to keep the product at disconnected and isolated status. You cannot operate with handle under this status.

#### 4.7 Basic Electrical Control Principles

Refer to Table 7 for NKB1 auxiliary circuits

**Table 7 NKB1 auxiliary circuits**

Accessories	NO	NO	NC	NO	NC	a	b
	13 	23 	31 	41 	41 	95 	201 
14	24	32	44	42	98	202	
06 auxiliary	√	√	√	√	√	√	√
	AC-15 Ie:5A Ue:400V			AC-15 Ie:3A Ue:230V			
Note: auxiliary a (95/98): used as fault release signal port; auxiliary b (201/202): used as firefighting type fault alarm signal port.							

Secondary power	Power protection	Power signal	On-site manual control		Auxiliary signal			Fault signal	
			Start	Stop	Self-lock	Operation	Stop	Stop	Alarm

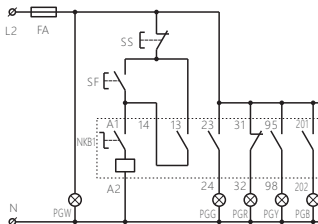

Note: This figure is applicable to on-site direct control of single equipment under normal operation by using start/stop button.

**Figure 3 Manual panel + on-site control wiring diagram**

Secondary power	Power protection	Power signal	On-site manual control	Auxiliary signal			Fault signal	
				Self-lock	Operation	Stop	Stop	Alarm

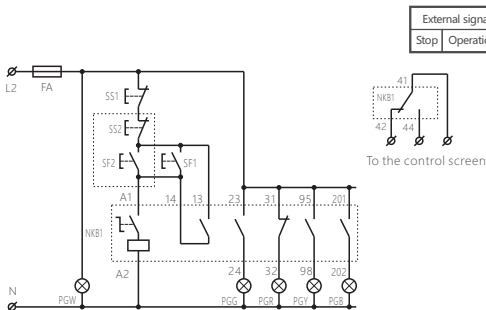

Note: This figure is applicable to on-site and remote control of single motor under normal operation.

**Figure 4 Manual panel + on-site control + remote control**

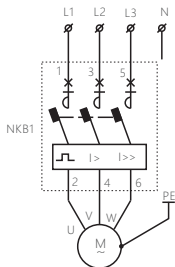

Figure 5 Motor control diagram

## 5 Installation

### 5.1 Outline and Installation Dimensions

Unit: mm

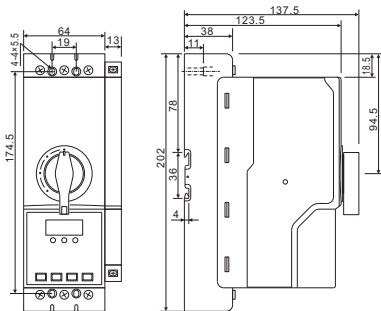

Figure 6 NKB1-45

Unit: mm

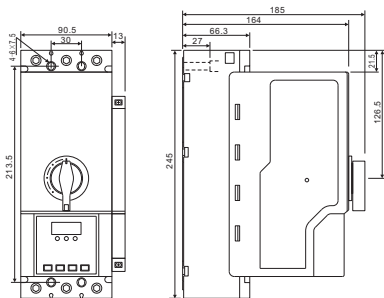

Figure 7 NKB1-125

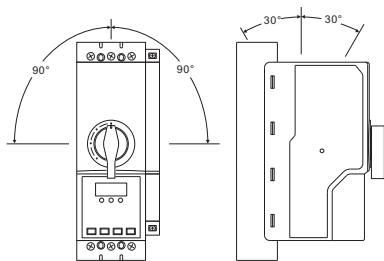

Figure 8 Installation positions

## 5.2 Installation, Commissioning and Operation

Check if the operation knob is at disconnect position and can function normally before installing the switch. "AUTO" means the main circuit is connected. "TRIP" refers to release position, namely the position of free release in case of circuit fault. Do not operate the switch before the circuit fault is cleared. "OFF" refers to the disconnect position of main circuit. Freely released switch can only be reset and ready to release again after the operation knob is rotated to "RESET" position.

Before installing and operating the switch, check if the power supply voltage of coil and accessories is consistent with that stated in instructions and is applicable to the actual control circuit.

When the control power voltage is (85%~110%) Us, if you rotate the knob to "AUTO" position, the electromagnet will close reliably, if you rotate the knob to "OFF" position, the electromagnet will release reliably.

The operation current setting value of switch release is set before delivery, user can adjust the value according to actual needs.

The switch can provide overload, overcurrent, phase failure, overvoltage and undervoltage protections and send out alarm through indicators.

NKB1 can still operate after disconnecting short circuit current, but you need to check the status of the switch.

## 6 Maintenance

### 6.1 Maintenance and care

- Remove dust daily; check the tightness of terminal screws, check the status of wires.
- If the product is stored under the environment specified in the instructions or shut down for half a year, please check the status before use.
- Prevent the product from rain and falling during operation and storage.

### 6.2 Notes

When using motor with larger power (above 11kW), user should take start torque, current amplification, voltage drop and circuit capacity into consideration and select proper reduced-voltage starting method. Usually, voltage should not be reduced to lower than 80% of rated value, and the selected current amplification factor should not be bigger than (4~5). Start the motor with proper load so that the NKB1 electromagnet can operate reliably.

When setting switch overload protection parameters, we suggest to choose F0, F1, F2 for 45 type product with rated current of 25~45A; choose F0, F1, F2 for 125 type product with rated current of 100~125A. You can choose more overload protection curves for other rated currents.

### 6.3 Analysis and Troubleshooting of Common Faults

**Table 8 Analysis and Troubleshooting of Common Faults**

No.	Symptoms	Cause analysis	Troubleshooting method
1	The switch does not work after being powered on	1.Check if the knob is at "AUTO" position 2.Check A1, A2 control power	Rotate the operation knob to "AUTO" position and connect the control power correctly
2	Switch coil burnt after powered on	Check A1, A2 control power for connection and short circuit	Check control circuit or replace switch
3	Switch does not lock by itself	1.Check auxiliary self-locking contact 2.Check A1, A2 control power voltage	Connect auxiliary circuit correctly; auxiliary circuit fault; replace switch
4	Motor does not work after the switch is closed	Check power circuit, load	Check and repair circuit, connect the power correctly

No.	Symptoms	Cause analysis	Troubleshooting method
5	Switch provides protection after motor starts	Check 95, 98 auxiliary circuit or handle position, identify the cause for fault release	Check load circuit (short circuit), adjust load and switch parameters; or replace switch
6	Switch provides protection after running with load for a period of time	Protection of the smart controller of the switch, check fault records, check circuit	Check and repair circuit; adjust setting parameters according to load or replace switch
7	Motor burnt, switch does not provide protection	Check switch parameter settings, check fault, check circuit	Set up parameters according to load, check and repair circuit or replace switch

## 7 Environmental Protection

In order to protect the environment, when the product or its parts are scrapped, please properly dispose of them as industrial wastes; or be sent to the recycling station for assortment, dismantling and recycling.

**CHNT**

**QC PASS**

NKB1

Control and Protection Switch  
IEC/EN 60947-6-2

**Check 01**

---

Test date: Please see the packing

---

**ZHEJIANG CHINT ELECTRICS CO., LTD.**

---

# CHINT

CHINT ELECTRICS

## NKB1 Control and Protection Switch User Instruction

### Zhejiang Chint Electrics Co., Ltd.

Add: No.1, CHINT Road, CHINT Industrial Zone, North Baixiang,  
Yueqing, Zhejiang 325603, P.R.China

E-mail: [global-sales@chint.com](mailto:global-sales@chint.com)

Website: <http://en.chint.com>

