

NJJ7-M  
Counting Relay

---

**User Instruction**

---

## Safety Warning

---

- ① Only professional technicians are allowed for installation and maintenance.
- ② Installation in any damp, condensed-phase environment with inflammable and explosive gas is forbidden.
- ③ When the product is being installed or maintained, the power must be switched off.
- ④ You are prohibited from touching the conductive part when the product is operating.
- ⑤ The product shall be stored, installed and used in accordance with the rated control power supply voltage and specified conditions indicated in the user instructions.
- ⑥ The products shall be properly wired in strict accordance with the wiring diagram.

## 1 Use Purpose

NJ7-M counting relay (hereinafter referred to as the counter) is mainly used as counting or counting control component in the control circuit with AC frequency of 50Hz/60Hz, rated control power supply voltage up to 240V and DC rated control power supply voltage up to 240V.

## 2 Key Technical Parameters

Table 1 Ambient Conditions

Normal use conditions	Ambient temp.: -5°C~+40°C; average value within 24h not exceeding +35°C; altitude not exceeding 2,000m.
Atmospheric conditions	RH shall not exceed 50% when maximum temperature is +40°C; in case of lower temperature, higher RH is allowed. Measures should be taken against occasional condensation due to temperature change.
Installation category	II
Transport and storage conditions	-25°C~+55°C

Table 2 Product Specifications and Main Technical Parameters

Model	NJ7-M
Output method	1 group of transfer contact, open-collector output (30VDC, 100mA max)
Counting digit	In CR Mode: 4 digits (4-digit red LED is the count value, 4-digit green LED is the preset value)
	In CT mode: 8 digits (green LED is the lower 4 digits, red LED is the higher 4 digits)
Counting speed	1 time/s, 30 times/s, 1000 times optional
Counting mode	Add, subtract, reversible A, reversible B, reversible C
Input signal	Contact input, sensor input (NPN type, PNP type optional)
External sensor power supply	12VDC, 30mA max
Value setting	Setting range 0.01~9.99
Output mode	N, F, C, R, K, P, Q, A

Table 2 (continued)

Model	NJJ7-M
Output time	The output time can be set as 0.01s~9.99s (when the output mode is C, R, K, P, Q, A)
Installation method	Panel type
Power-off memory	More than 10 years (settable)

Table 3 Main Circuit and Auxiliary Circuit Technical Parameters

No.	Product Model	NJJ7-M		
1	Rated control supply voltage $U_s$ (V), frequency (Hz)	AC/DC100V~240V, 50Hz/60Hz; DC24V		
2	Allowable fluctuation range of rated control power supply voltage	85% $U_s$ ~110% $U_s$		
3	Agreed free air heating current $I_{th}$ (A)	5		
4	Rated operating voltage $U_e$ (V)	AC220V	AC380V	DC220V
5	Use type under rated operating voltage and rated operating current $I_e$ (A)	AC-15	AC-15	DC-13
		0.75A	0.47A	0.27A
6	Rated insulation voltage $U_i$ (V)	415V		
7	Rated impulse withstand voltage $U_{imp}$ (kV)	4		
8	Enclosure protection class (if applicable)	IP20		
9	Pollution class	Class 3		
10	Type and maximum value of short circuit protection	RT36-00/6A		
11	Size of terminal tightening screw (or nut)	M3		
12	Torque of terminal tightening screw (N·m)	0.5		
13	Electrical life / mechanical life (10,000 times)	10/100		

Table 4 Immunity to Interference

No.	Test type	Test level
1	Electrostatic discharge immunity test	8kV (air discharge)
2	RF electromagnetic field immunity test	10V/m
3	Electrical fast transient/burst immunity test	2kV/5kHz on the power supply side
4	Surge immunity test	1kV (wire to wire)

## 3 Installation

3.1 Outline and installation size: see Figure 1~ Figure 2, unit: mm.

3.2 Panel diagram: see Figure 3; Wiring diagram: see Figure 4~ Figure 6; Logic selection diagram: see Figure 7; Output wiring diagram: see Figure 8.

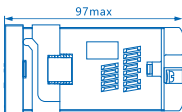

Figure 1 Outline Size

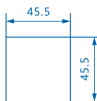
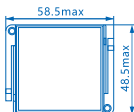

Figure 2 Hole-cutting Size

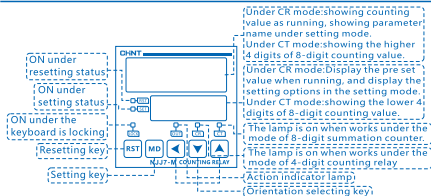

Figure 3 Panel Diagram

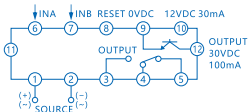

Figure 4 Wiring Diagram

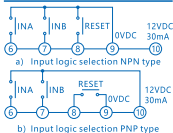
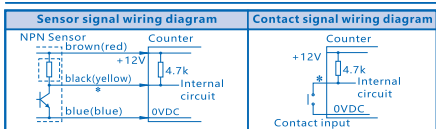
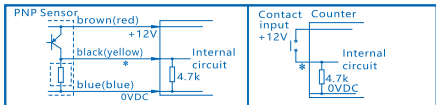

Figure 5 Contact Input Wiring Diagram



Note: \* is INA\INB. a) Input logic selection NPN type



Note: \* is INA\INB. b) Input logic selection PNP type

**Figure 6 Wiring Diagram of Sensor Input**

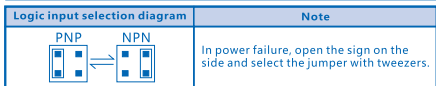

**Figure 7 Logic Input Selection Diagram**

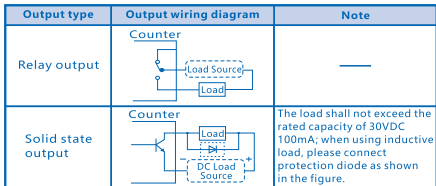

**Figure 8 Output Wiring Diagram**

### 3.3 Counter setting

#### 3.3.1 Parameter setting

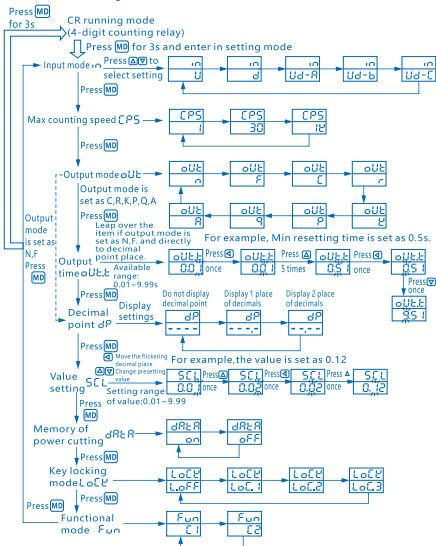

Notes: C1 is the 4-digit counter mode, C2 is the 8-digit reversible sum counter mode; when you select C2, press **MD** for 3s to enter the CT sum counter mode.

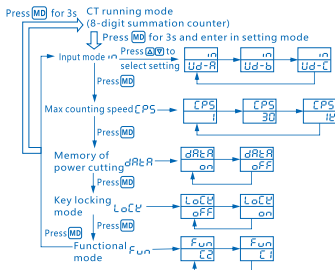

Notes:

- 1) C1 is the 4-digit counter mode, C2 is the 8-digit reversible sum counter mode; when you select C1, press **MD** for 3s to enter the counting relay mode.
- 2) All setting parameters are automatically stored before power failure, and the counting value is determined according to the setting.
- 3) If no button action occurs in the setting mode, it will automatically return to the run mode after 60s.

### 3.3.2 Preset value setting in CR mode



Example: set the preset value to 500

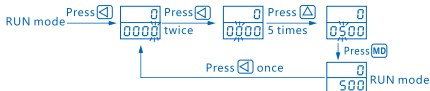

### 3.3.3 Value setting function in CR mode

This function is used to measure the length, flow, position, etc. The amount represented by one pulse is the unit value (user defined), and the counter realizes the metering function according to the set unit value.

New display value = original display value + (or -) unit value × number of pulses

Example: when the set value is 0.02 and the counting mode is add counting, the current count value is 0.10 (the decimal point display is set as: two decimal places are valid). After two pulses are given to the counter, the current count value is 0.14.

### 3.3.4 Lock mode description

The product has a lock mode to prevent press errors, see Table 5.

**Table 5 Lock Mode**

Working mode	Lock mode	Lock function description
In CR mode	LoFF	Means no lock status, the lock light of the front panel is off
	LoC.1	Means <b>RST</b> is locked, the lock light of the front panel is on.
	LoC.2	Means <b>◀ ▼ ▲</b> are locked, the lock light of the front panel is on.
	LoC.3	Means <b>RST ▶ ▼ ▲</b> are locked, the lock light of the front panel is on.
In CT mode	off	Means no lock status, the lock light of the front panel is off, and the reset button is valid.
	on	Means lock status, the lock light of the front panel is on, and the reset button is invalid.

Notes: The buttons **◀ ▼ ▲** are invalid in the CT mode.







### 3.4 Counting mode of the counter

This counter has 5 counting modes in CR mode: add, subtract, reversible A, reversible B and reversible C; it has 3 counting modes in CT mode: reversible A, reversible B and reversible C, see Table 6 for details.

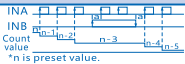
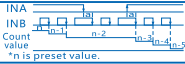
**Table 6 Counting Mode**

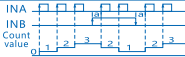
Counting mode	Working sequence diagram	Note
<b>U</b> Add counting mode		INA rising edge count, INB input, stop counting.
		When INA is input, INB input falling edge count.

Table 6 (continued)

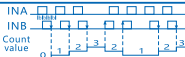
Counting mode	Working sequence diagram	Note
 Subtract counting mode	 <p>Count value *n is preset value.</p>	INA rising edge count, INB input, stop counting.
	 <p>Count value *n is preset value.</p>	When INA is input, INB input falling edge count.
 Reversible counting mode A	 <p>Count value</p>	Add count when INA is input, Subtract count when INB is input.
 Reversible counting mode B	 <p>Count value</p>	Add count when INA is input, Subtract count when INB is input.
 Reversible counting mode C	 <p>Count value</p>	Automatically distinguish between positive and negative rotation, add or subtract counting.

Notes:

- 1) In the case of sensor input, the high level is 5V~30V, the low level is 0V~2V; In the case of contact input, the user does not need to consider high and low levels.
- 2) a minimum signal width or more, b 1/2 minimum signal width or more.

### 3.5 Output mode of the counter

This product has 8 output modes, see Table 7.

Table 7 Output Mode









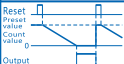
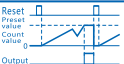
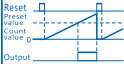
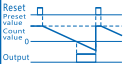
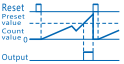
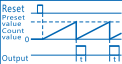
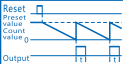
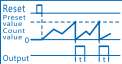
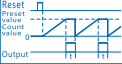
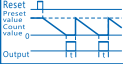
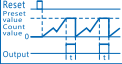

Output mode	 add counting mode	 subtract counting mode	Reversible counting mode A, B, C
$\overline{Q}$ (N)			
F (F)			

Table 7 (continued)

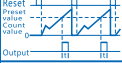
Output mode	↑ add counting mode	↓ subtract counting mode	Reversible counting mode A, B, C
$\text{C}$ (C)			
$\text{r}$ (R)			
$\text{K}$ (K)			
$\text{P}$ (P)			
$\text{Q}$ (Q)			
$\text{A}$ (A)			

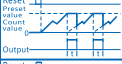
Notes:

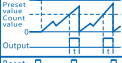
- 1) The counter has 8 output modes in CR mode, and has no output in CT mode.
- 2)  $t$  is the set value of the output time  $\text{OUT}_{\text{CT}}$ .

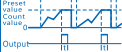
### 3.6 Installation method of the sensor

The installation method of the sensor of reversible counting mode C is as follows:



### 3.7 Instructions for use

- 1) 100ms after power on is the rising period of power supply, 700ms after power off is the falling period of power supply. So input the signal after power on for 100ms, and turn on the power after power off for 700ms.
- 2) Make sure the power is off when selecting the input logic (NPN/PNP).
- 3) The matching counting speed must be selected according to the speed of signal input: when the counting speed is 1 time/s, the signal pulse width should be  $\geq 500\text{ms}$ ; when the counting speed is 30 times/s, the signal pulse width should be  $\geq 16.7\text{ms}$ ; When the counting speed is 1000 times/s, the signal pulse width should be  $\geq 500\mu\text{s}$ . If contact input is applied, please use the low speed mode, otherwise miscount will be generated.
- 4) When the counting signal is contact input, please use the contact with good contact to prevent the counter from count error due to the serious rebound of the contact. If necessary, a capacitor of  $1\mu\text{F} \sim 10\mu\text{F}$  may be connected at both ends of the contact to enhance the counting reliability.
- 5) The counting signal line shall not use the same pipe with the power supply to avoid interference. The signal line should be as short as possible and shielded wire should be used.

## 4 Maintenance

4.1 The terminal of the counter should be tightened on a regular basis.

4.2 Avoid squeezing the product; the product should be stored in a well-ventilated place.

4.3 For equipment that may cause material economic losses or personal safety, safety measures such as secondary circuit protection should be taken.

**Table 8 Fault Analysis and Troubleshooting**

Symptoms	Cause analysis	Troubleshooting method
The nixie tube does not display.	Whether the wire and the terminal are in reliable contact, and whether the power terminal is correctly wired.	Connect wires reliably according to the user instructions.
The product fails to count.	Whether the signal wiring is wrong, whether the input voltage is too low, whether the input logic (NPN / PNP) is correct, and whether the counting speed matches the signal width.	Connect wires reliably according to the user instructions, and confirm the input logic is correct and the counting speed is proper.

## 5 Environmental Protection

In order to protect the environment, the product or product parts should be disposed of according to the industrial waste treatment process, or be sent to the recycling station for assortment, dismantling and recycling according to local regulations.

---

# CHINT

## QC PASS

NJJ7-M

Counting Relay  
IEC/EN 60947-5-1

JDQ Check 10

---

Test date: Please see the packing

---

ZHEJIANG CHINT ELECTRICS CO., LTD.

---

# CHINT

CHINT ELECTRICS

## NJJ7-M Counting Relay User Instruction

### Zhejiang Chint Electric Co., Ltd.

Add: No.1, CHINT Road, CHINT Industrial Zone, North Baixiang,  
Yueqing, Zhejiang 325603, P.R.China

E-mail: [global-sales@chint.com](mailto:global-sales@chint.com)

Website: <http://en.chint.com>

